

# PRE-DOCKING INSPECTION



ETSXXX

Windlass

Revision: 00

Vessel Name : IMO No. :

Shipyard : Hull No. :

Mooring Winch description :

Serial No: : Year built :

## 1 Mooring Winch – Checkpoints

Item	Description	Checked "OK"	Comment
1	Condition of hydraulic hoses and cylinders		
2	Shaft seals condition		
3	Gearwheel condition		
4	Oil leakage		
5	Corrosion		
6	Gear oil samples taken or performed by crew		
7	Band brake properly adjusted according to instruction manual		
8	Foundations (endstoppers, chockfast, foundation bolts)		
9	Declutching condition and operation		
10	Wear on lever knob for coupling		
11	Claw coupling surfaces		
12	Band brake operation		
13	Band brake lining thickness		
14	Winch drum bushing clearances (See last page)		
15	Wear of Bearing Bracket split bearings		
16	Running test		
17	Oil level in gear box		

## 2 Hydraulics – Checkpoints

Item	Description	Checked "OK"	Comment
1	Running test		
2	If winch is not running smooth check the hydraulic valve settings and nozzles.		
3	Condition of piping		
4	Hydraulic oil leakage valve block		

# PRE-DOCKING INSPECTION

ETSXXX

Windlass

Revision: 00

5	Remote control operation and settings		
6	Remote control hydraulic oil leakage		

### 3 Mooring Winch – Drum bushing clearance

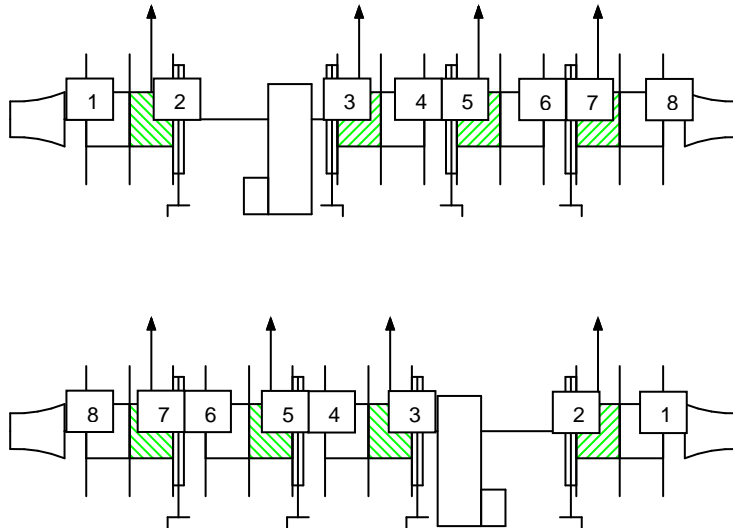

*Cross over the building form which is not applicable*

Measured drum bushing clearance							
1	2	3	4	5	6	7	8

Inspection performed by : <Name and Signature>

Date of inspection : <Date>